

# ReachOut

Vol. 14 | January 2024



Dear Business Associate,

I trust this message finds you in good health and prosperity. As we reflect on the journey of the past year, it is with great pride and enthusiasm that I share the news of FIBRO India's monumental success in 2023. The year has been nothing short of remarkable, marked by significant achievements and milestones that have set new benchmarks for our organization.

Over the past year, FIBRO India has received accolades from major OEMs and Die makers, yet we remain focused on innovation. We expanded our Cam Series by introducing three additional sizes of Aerial Cam Units and a wide range of Guideposts. Recognizing the need for the localization of Centering Units, we have commenced manufacturing in our India facility, aligning with the contemporary requirements of our clientele. Additionally, we proudly unveiled FIBRONXT 200, a High-Precision and High-Speed Rotary Table.

Beyond product enhancements, we've elevated our online presence by leveraging technological advancements to transform both our Webshop and Website. Our primary focus has been on streamlining and optimizing the user experience, ensuring it is intuitive and efficient for you to explore and purchase our products. The redesigned website aims to provide essential information within a few clicks, offering a seamless online journey. To further assist you, we've introduced Product Assistants (configurators) on our website, enabling customers to make swift and error-free product selections. Our goal is to simplify your online experience and ensure easy access to relevant details.

I extend a warm invitation for you to join us at the upcoming DMI 2024 Exhibition, where FIBRO India will showcase its latest product developments at Stall D06 in Hall 1. It will be an excellent opportunity for you to experience firsthand our commitment to pushing the boundaries of possibilities and delivering unparalleled quality rooted in FIBRO KIP+ (Know-How, Innovation, and Precision).

We express our deepest gratitude for your steadfast support, and many more updates capturing the success of 2023 are covered in this newsletter. Should you have any questions or feedback, please do not hesitate to reach out to us.

Wishing you a Very Happy and Prosperous New Year!



**Vivek Nanivadekar**  
Executive Director

## 2<sup>nd</sup> PARTNERS MEET 2023

FIBRO firmly believes in fostering strong partnerships by working together to achieve unparalleled success. We organized the 2<sup>nd</sup> Partners' Meet, a momentous event that exemplifies our commitment to nurturing partnership ties.



Our Goal was to explore Innovative Solutions leading to Cost-Effectiveness and strengthening our Supply Chain, aligning our manufacturing processes with OEM demand, deliberating on Challenges faced, and adopting the latest Technology in operations.



We extend our heartfelt gratitude to all our Partners for their participation, as it is through their unwavering support, we embark on an inspiring quest together.

## OUR EXECUTIVE DIRECTOR AS ONE OF THE ESTEEMED PANALIST IN PANEL DISCUSSION 75 YEARS 75 INNOVATION PROGRAM ORGANIZED MACHINE MAKERS

Recognizing the significance of advancing the manufacturing sector, Machine Maker embarked on a significant initiative titled "75 Years | 75 Innovations." This two-day program featured a dedicated second day for Technical Sessions.

Guided by D K Sharma, the esteemed Past President of TAGMA, the session delved into discussions that brought the evolving landscape of toolmaking to the forefront. Mr. Amar Kulkarni, Global Product Evangelist of M/s Polyworks India, skillfully facilitated the conversation, ensuring a thorough exploration of each insight.

The panel included industry luminaries who have significantly shaped the trajectory of the sector: Phani Kumar Uppala, Director-Engineering of M/s Tesin Products Pvt Ltd; Vivek Nanivadekar, Executive Director of



FIBRO India; Bibhu Prasad, Director of I-MOLD JSB Polymers; and Aditya Kumar, Managing Director of Marcopolo Products. Together, they shared their perspectives, fostering a session filled with high energy as they dissected the sector's

challenges, opportunities, and potential transformations.

We express our gratitude to Machine Maker for providing us an opportunity to become a part of the Grand Event.

# INTERNATIONAL TOOLING SUMMIT 2023, ORGANIZED BY TAGMA



The Tool and Gauge Manufacturers Association of India (TAGMA India) organized the International Tooling Summit in Bengaluru on August 24 and 25, 2023, the flagship event catering the Tool and Die Industry.

The event provided FIBRO India with a fantastic opportunity to engage with potential customers and industry experts. The technical Sessions from Industry Experts provided an industry growth blueprint. The fast implementation of the latest technology in the industry assured future growth trajectory.

On behalf of FIBRO India, Mr. Steffen Domay, Business Development Manager from FIBRO GmbH, a passionate enthusiast in Standard Parts for blank sheet metal stamping dies, presented **'Inspirations for Enhancing the Value Chain of Your Sheet Metal Production.'**

Besides exhibiting an entire range of Standard Parts for Press Tools and Dies and Standard Parts for Mould Making, FIBRO India Introduced our patented Technology WPM, making Press shop Industry 4.0 ready. The Wireless Pressure Monitoring enables remote monitoring of the pressure and temperature of your installed FIBRO Gas Springs.



# SYMPOSIUM ON AUTOMATION AND ROBOTICS, ORGANIZED BY IMTMA ON 5-6 OCT 2023

In an era where Automation and Robotics are transforming industries at an unprecedented pace, staying at the forefront of technological advancements is crucial. FIBRO India is glad to be part of the 6th edition of the Symposium on Automation & Robotics organized by IMTMA, 5-6 October 2023 in Pune. The Symposium served as a superb forum for engaging with industry experts and highlighting cutting-edge advancements in Automation and Smart Manufacturing Techniques.

FIBRO India presented Rotary Tables designed for Automation Systems, featuring a broad product range known for precision, substantial processing strength, and minimal cycle times. They enhanced overall production efficiency.

Although the focus was on Automation and Robotics, being an Industry 4.0 Ready technology, FIBRO India displayed a Wireless Pressure Monitoring System. The WPM remotely monitors the pressure and temperature of your installed FIBRO Gas Springs, minimizing the possibility of unwanted Stamping parts production.

Our participation in the event significantly enhanced our overall experience. Besides exhibiting our high-precision product range, we had a fruitful discussion with fellow manufacturers and industry leaders, fostering valuable collaborations and knowledge-sharing opportunities.



# NEW PRODUCTS

**FIBRO India: Elevating Customer Choices, Empowering Them to Add New Possibilities to Their Cart!**

## FIBROTOR Series Trunnion

Indigenized FIBROTOR series TRUNNIONS is used alongwith FIBROTOR series Vertical Rotary tables as support tables for applications such as Welding, Assembly, Handling and many more.

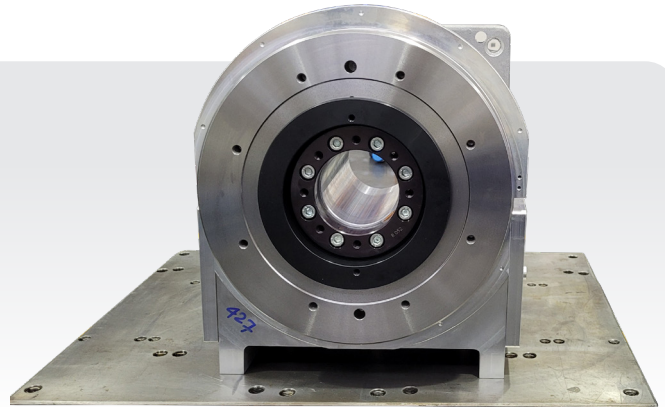

## Centering Unit

Our simple designed Locating Pins perform exceptionally when it comes to holding a component in a high-speed press operation. The conical surfaces are induction hardened and the Centering units are 16MnCr5, heat treated.



The Made in India Centering units are ready in stock and be dispatched immediately after order placement. In addition, you can now order them easily from our Webshop!

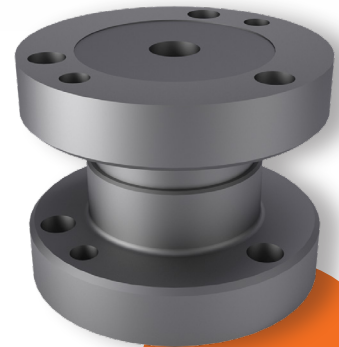

**WIDE VARIETY AVAILABLE**

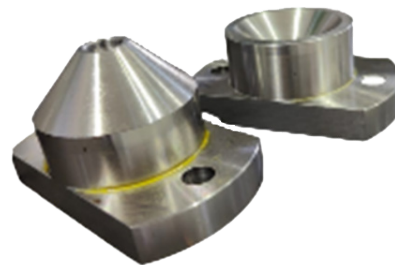

IS 4296  
  
PART 2  
CM/L-7500259951

## FIBRO PUNCHES: One More Feat Achieved!

FIBRO Punches are BIS Certified.

We are glad to inform that FIBRO India has successfully completed the stringent evaluation for BIS certification process. Now onwards, FIBRO Punches manufactured in India are BIS Certified. The customers will certainly benefit from the certification as it ensures that the product meets stringent Quality and Safety Standards. The certificate instills confidence in product reliability and performance.

Our Range of Ground Precision Punches consists of a wide variety of Punch Profiles available in 8 different materials. We also have simplified and fastened the Punch Matrix selection process with our Easy-to-use Product Configurator.

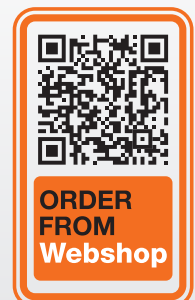

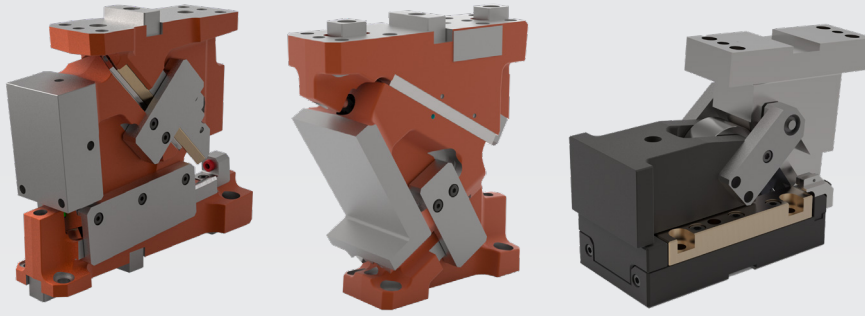

## Widest Width Cam Unit Ever Produced in India!

FIBRO India has developed 300 mm Cam Unit in its India manufacturing facility. The Aerial Cam unit 2016.202.300. are in true sense German Precision Crafted in India. The Cams will benefit our customers with High Retraction & Working forces, Higher precision even after a higher number of pressing cycles. The Cam is available in Compression Spring options and a provision for a Gas Spring option (depending on process feasibility). Due to design expertise, these cam units require minimal maintenance.

## FIBRO DNA Cam Units Most Compact Cam Series

### i. Our aerial cam units, 2016.27

**FCC-OT-LV-C series**, are distinguished due to its extremely compact overall dimensions. They are well suited for tools with small and medium-size strokes per lifetime, also convince with high working and retraction forces. The glide pairing of this cam unit series is performed in sintered/bronze sliding elements against a non-hardened cast surface. The wear elements of the guides are catalog items from our Standard Parts product range and offer excellent availability. The gas springs are accessible from the rear of the cam unit in all cam slide units in this series and can be disassembled within the tool. These gas springs, with the advanced safety features used in our cam units, provide the best possible safety standards according to the Pressure Equipment Directive.

### ii. Our FIBRO Die Mounted

**FCC 2016.15 series** cam units impress with a balanced adjustment of compact dimensions, high working forces and extremely high retraction forces. Thanks to the proven

and trusted guide concept, these units offer excellent precision and deliver excellent performance, even with the highest demands on service life.

The sliding surfaces of the cam slide units of this series are double-populated across all available sizes. All gliding rails are shouldered against any occurring shear forces. The wear elements of the guides are catalogue items from our Standard Parts product range and offer excellent availability.

With adequate provided free space, the gas springs of all cam units in this series can be accessed and disassembled within the tool from the rear.

### iii. Our Roller Cam Units series

**2017.43** has been used in various dies for many years. They allow a working angle which can be individually adapted to the necessary requirements and are ideal for use in punching operations.

a. The Roller Cam Units are available in four widths and different stroke lengths. In comparison to cam units,

the working angle in the permitted angular range can be selected virtually without restriction and without graduation.

b. The V-shaped guide, in combination with a solid roller, permits sufficiently high pressing forces and precise guidance. The guide, which is equipped with bronze or sintered sliding elements, reduces the required maintenance work, and allows simple repair in the event of wear.

c. These Cam Units are reset by gas springs. These gas springs used in these units, with the advanced safety features, are from our Standard Parts product range and offer the highest possible safety standard according to the Pressure Equipment Directive.

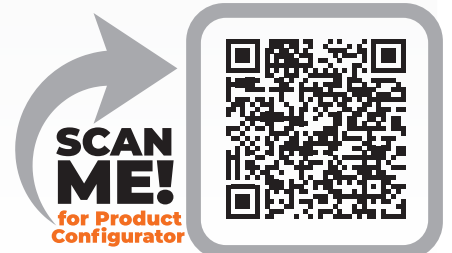

# EXHIBITION

## ACMEE 2023



In ACMEE Exhibition, FIBRO India Highlighted **15<sup>th</sup> Years of Making in India**, so the Social Media Campaign was directed towards Made in India Cam Units, Rotary Tables, Guide-Post, Punches and of course introduction of WPM technology and Made in India Cutting Table.

We had social Media posts (video) addressed in regional language. Even the stall had Welcome message in regional languages namely Tamil, Kanada, Telugu and Malayalam.



### PRODUCTS ON DISPLAY AT FIBRO INDIA STALL (HALL B STALL B74):

#### Rotary Tables

FIBROTOR ER/EM 10, ER/EM 11, ER/EM 12, ER/EM 14, ER/EM 15, F'TOR EM.NC 13, FIBRONEX 200.

#### Standard Parts

Cam Units, Punches, Gas Springs, WPM, Electric Transporter, Guide Elements, Recirculating Ball Bushes, Punches, Oilless Guide Elements, Lifting Elements, Guide Pillars, Guide Bushes, Compression Springs, Guide-Post, Dampers, Elastomers, Standard Parts for Injection Mould Making, OMCR.



## ENGIMACH 2023, December



The exhibition stands at the forefront of technological evolution and providing a dynamic platform for the latest advancements in Machine Tools. As an industry-leading event, we not only looked forward to the exhibition for product display and interactions but as a harbinger of the transformative trends set to revolutionize the sector.

At our **stall 41 in Hall 7**, customers experienced **FIBRO PRECISION, FIBRO KNOW-HOW** and **FIBRO INNOVATION** through our state-of-the-art Products.

FIBRO India showcased Rotary Tables for Machine Tools and Automation Systems, most comprehensive Rotary Table Range from one source. These Rotary Tables are used as swiveling and positioning axes, as workpiece carriers in machine tools, and in the field of assembly lines to make Product processes Efficient and Precise.



Our Stall also displayed Standard Parts tailored for Mould-Making and for Tools and Dies including Cam Units, Springs, and Punches. Latest technology, Wireless Pressure Monitoring System – to monitor FIBRO Gas Springs. Visitors had live experience of ordering Process with FIBRO India Webshop.



# CUSTOMER TESTIMONIALS



More than 25 years we are into Pharma Machine Manufacturing and **enjoy** an equally **long-term association** with **FIBRO India**. The team is very **cooperative** and always provides **win-win solutions**. Over the years, they are **not just** our Suppliers but **Business Partners**.

FIBRO provides **best quality Products**, and we are their **Happy Customers!**

**Shailesh Panchal**  
Deputy Manager- SQA and QC  
M/s IRM Enterprise Pvt Ltd

We are associated with **FIBRO India for close to 10 years** and are **absolutely happy** with the **Team** and their **products**. FIBRO Gas Springs and Ball Cages are regularly used in our stamping process. We also **encourage other Press Tools** to use **FIBRO products**.

**Kishan Patel**  
Purchase Department  
M/s Harsha Engineers International Ltd



# STOCK AND SELL

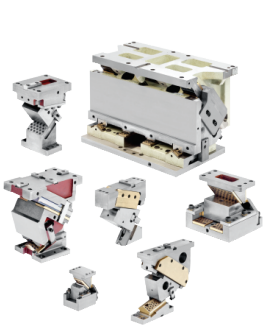

**Cam Units**  
500+ in stock



**Centering Unit**  
200+ in stock



**Prismatic Guide Set**  
500+ in stock

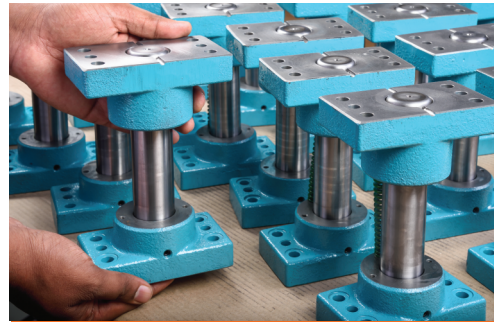

**Guide Post**  
3500+ in stock



**Guide Elements**  
12,000+ in stock



**CI Wear Plate**  
2000+ in stock



**Gas Spring**  
7500+ in stock



**Compression Spring**  
20000+ in stock

And Many More...

## PEARLS OF WISDOM

Anyone who stops learning is old, whether at twenty or eighty. Anyone who keeps learning stays young.”

– Henry Ford

## UPCOMING EVENTS



FIBRO India  
Sponsored  
18<sup>th</sup> January  
2024, Bengaluru



13<sup>th</sup> DIE & MOULD INDIA INTERNATIONAL EXHIBITION  
Feb 14-17, 2024  
Bombay Exhibition Centre, Mumbai, India  
Hall 01, Stall D06

**FIBRO INDIA PRECISION PRODUCTS PRIVATE LIMITED****Head Office & Works:**

FIBRO India Precision India Pvt Ltd  
Plot No-A-55, Phase II, Chakan M.I.D.C,  
Tal - Khed, Pune - 410501, INDIA.  
Phone: +91-2135-670-900  
Email: info@fibro-india.com

**THE LÄPPLE GROUP**

LÄPPLE AUTOMOTIVE  
FIBRO  
FIBRO LÄPPLE TECHNOLOGY  
LÄPPLE AUS- UND  
WEITERBILDUNG

**North & East Region****Mr. Sourabh Mittal**

Area Manager – Business Development  
Phone +91-8743 02 58 80  
Email: sourabh@fibro-india.com

**Mr. Harshit Dixit**

Asst. Area Manager – Business Development  
Phone: +91-8699 22 8140  
Email: h.dixit@fibro-india.com

**Mr. Jayendrasinh Parmar**

Regional Manager – Business Development  
Phone: +91-9998 76 61 93  
Email: jayendra@fibro-india.com

**West Region****Mr. Prasad Ambikar**

Regional Manager – Business Development  
Phone: +91-9922 94 08 31  
Email: prasad.ambikar@fibro-india.com

**Mr. Rohit Tiwari**

Regional Manager- Business Development  
Phone +91-9607 97 89 65  
Email: r.tiwari@fibro-india.com

**South Region****Mr. Anbalagan Shan**

Regional Manager – Business Development  
Phone: +91-7871 73 29 30  
Email: anbalagan@fibro-india.com

**Mr. Manjunatha T**

Asst. Manager – Business Development  
Phone: +91-9511 92 19 92  
Email: manjunatha@fibro-india.com

**Mr. Mohammed Ismail**

Regional Manager – Business Development  
Phone: +91-9886 24 61 26  
Email: ismail@fibro-india.com

**Our Exclusive Channel Partners****VETO Clamping Systems Pvt Ltd**

Plot no.- 7A,Kila No-5,Pali Road  
Near Radha Swami Satsang, Sohna Road  
Faridabad (HR)-121005  
Phone: +91 9811 65 00 75  
Email: info.vetoclamps@gmail.com

**Legend Tool Tech**

Ground Floor, Highway No -84, Surya City  
Phase-1, AnekalChandapura Road, Chan-  
dapura Bangalore Rural, Karnataka - 560099.  
Phone: +91-9900 73 11 69  
+91-8712 33 12 80  
Email: legendtooltech@yahoo.com;  
sales.blr@legend-group.in

**Hydro Serve Systems**

68A /2, SIDCOIndustrial Estate,  
Ambattur, Chennai-600098.  
Phone: +91-9884 48 89 01  
Email: hydroserve-system@gmail.com

**G M Precision**

92 Mehar Singh Colony, Tripuri,  
Patiala, Punjab 147004.  
Phone: +91- 9914 96 79 65,  
+91-7889 12 30 88  
Email: info.gmprecision@gmail.com

**S. K Enterprise**

H.No 403, Sidhrawali Gurugram (HR) 122413  
Phone: +91 7082376808  
Phone: +91- 9466 28 65 10  
Email: 007skenterprises@gmail.com

**Saraswati Industrial Corporation**

N-6, ShivalikNagarss  
B.H.E.L., Ranipur, Haridwar  
Uttarakhand-249403  
Phone: +91- 9760 03 08 35  
Email: saraswatiindcorp@gmail.com

**Aura Engineering**

#218-A2, 3rd Floor, Sathyamoorthy Road,  
Opp.Tharakaram Silk House, Ram Nagar,  
Coimbatore - 641009.Tamil Nadu.  
Phone: +91 -8754 01 54 84,  
+91 9787 87 67 39  
Email: sales@auraengg.in

**R and W Tooling Solutions Pvt Ltd**

Shop No.3, Survey No. 594,  
Chikhali, Pune Maharashtra 411027  
Phone: +91 -8237 70 80 69  
Email: dnyaneshwar.waman@randwtoolings.com